

CONA® All-in-one - Steam trap station with integrated inlet and outlet valves

CONA®B All-in-one
Bimetallic steam trap
ANSI150 / 300

- with flanges (Fig. 60A....1)
- with screwed sockets (Fig. 60A....2)
- with socket weld ends (Fig. 60A....3)
- with butt weld ends (Fig. 60A....4)

Forged steel
Stainless steel
Fig. 60A

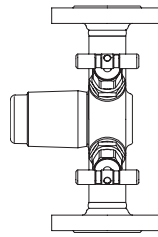

Page 2

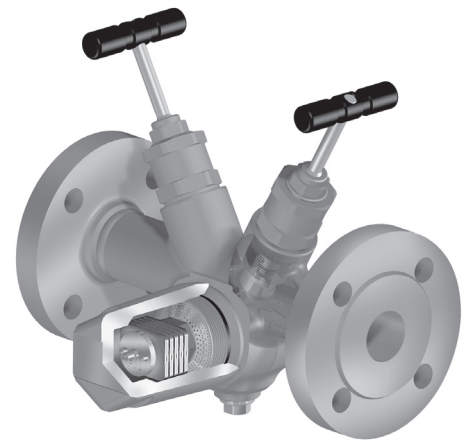

CONA®B All-in-one

CONA®M All-in-one
Thermostatic steam trap
ANSI150 / 300

- with flanges (Fig. 61A....1)
- with screwed sockets (Fig. 61A....2)
- with socket weld ends (Fig. 61A....3)
- with butt weld ends (Fig. 61A....4)

Forged steel
Stainless steel
Fig. 61A

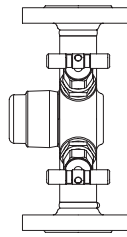

Page 4

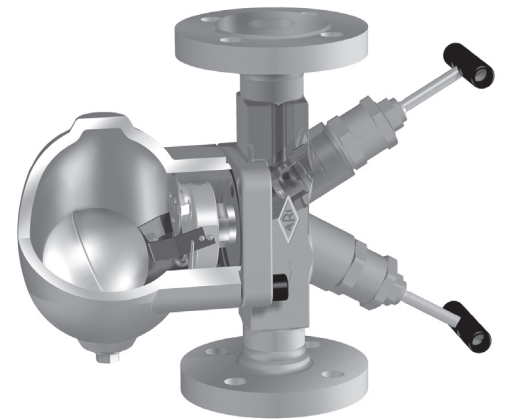

CONA®S All-in-one

CONA®TD All-in-one
Thermodynamic steam trap
ANSI150 / 300

- with flanges (Fig. 64A....1)
- with screwed sockets (Fig. 64A....2)
- with socket weld ends (Fig. 64A....3)
- with butt weld ends (Fig. 64A....4)

Forged steel
Stainless steel
Fig. 64A

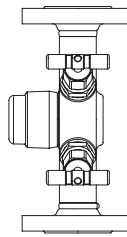

Page 6

CONA®SC All-in-one
Ball float steam trap
ANSI150 / 300

- with flanges (Fig. 63A....1)
- with screwed sockets (Fig. 63A....2)
- with socket weld ends (Fig. 63A....3)
- with butt weld ends (Fig. 63A....4)

Forged steel
Stainless steel
Fig. 63A

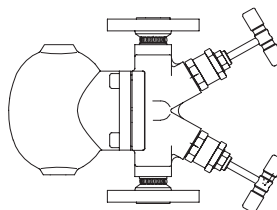

Page 10

Features:

- Robust and resistant to water-hammer
- Integrated non return protection
- Mounting position senkrecht or waagrecht
- The controller maybe changed without disturbing the pipe work
- Internal strainer
- Pressure test acc. to API 598

CONA®B/M/TD All-in-one:

- For discharging of slight to highly sub-cooled condensate
- Optimized design for quick installation
- Gasket-free sealing of the screwed cap

CONA®S All-in-one:

- Back pressure-free condensate discharge
- Rapid system start-up due to thermostatic airventing capsule

CONA® B All-in-one - Bimetallic steam trap with integrated inlet and outlet valves
(Forged steel, Stainless steel)

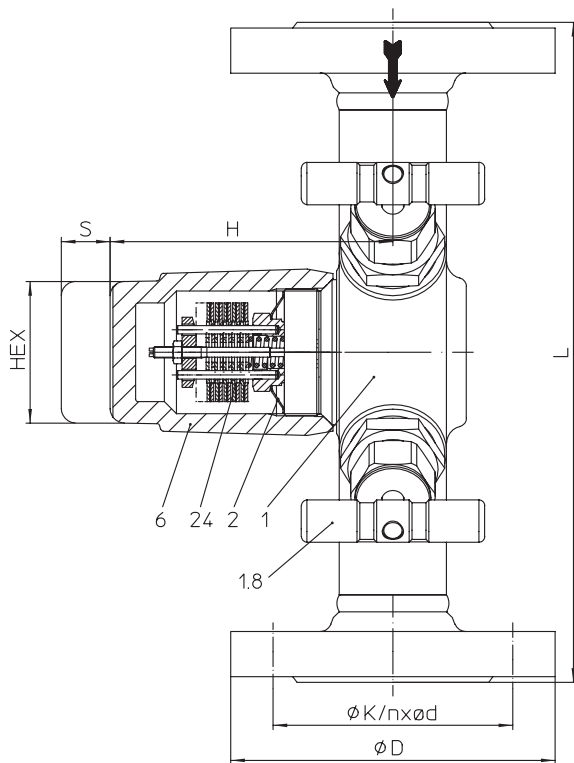

Fig. 60A....1 with flanges

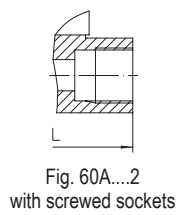

Fig. 60A....2 with screwed sockets

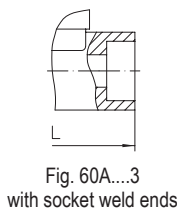

Fig. 60A....3 with socket weld ends

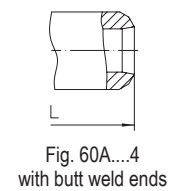

Fig. 60A....4 with butt weld ends

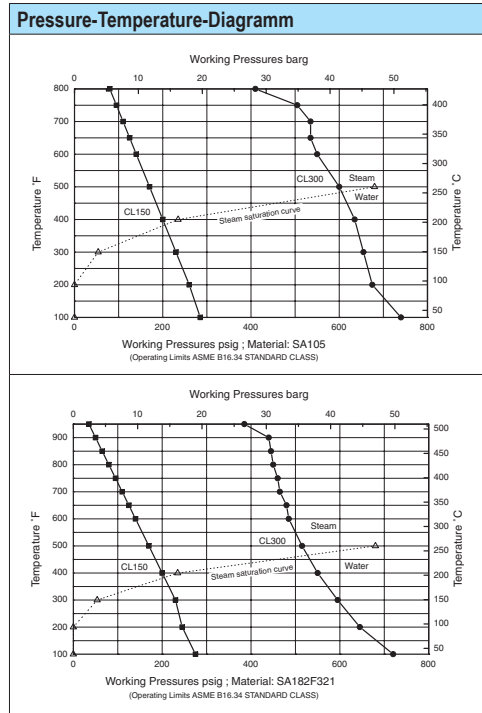

Figure	Nominal pressure	Material	NPS	Operating pressure PS	Inlet temperature TS	allowable differential pressure Δ PMX	for controller
42.60A	ANSI150	SA105	1/2" - 1"	13 barg	225 °C	32 bar 22 bar 13 bar	R32 R22 R13
				5,5 barg	427 °C		
45.60A	ANSI300	SA105	1/2" - 1"	32 barg	411 °C		
				22 barg	427 °C		
52.60A	ANSI150	SA182F321	1/2" - 1"	13 barg	225 °C		
				2,4 barg	510 °C		
55.60A	ANSI300	SA182F321	1/2" - 1"	32 barg	377 °C		
				22 barg	510 °C		

DIN/EN-Constructions refer to data sheet CONA®All-in-one

Types of connection Other types of connection on request.

- Flanges1 _____ acc. to ASME B16.5
- Screwed sockets2 _____ NPT thread acc. to ANSI B1.20.1 or Rp thread acc. to DIN EN 10226-1
- Socket weld ends3 _____ acc. to ASME B16.11
- Butt weld ends4 _____ ASME B16.25 (Note restriction on operating pressure / inlet temperature depending to design!)

Features

- Thermostatic steam trap with non-corrosive and robust water hammer proof bimetallic controller
- Mounting position senkrecht or waagrecht
- User-friendly handling, easy and quick access to the controller
- Automatic air-venting during start up and operation of the plant
- Non return protection
- With inside strainer
- Subcooling of condensate is continuously adjustable (observe the operation instructions)
- Maintenance simplified due to screwed cap without sealing
- The controller maybe changed without disturbing the pipe work

Controller (chooseable for operating range)

- Controller R13 uo to inlet pressure: 13 bar
- Controller R22 uo to inlet pressure: 22 bar
- Controller R32 uo to inlet pressure: 32 bar

Options (Design refer to page 3)

- Drain valve (Pos. 51)
- Ball valve for blow down (Pos. 56)
- Stop valve with bellows seal (Pos. 8)

Types of connection	Flanges			Screwed sockets Socket weld ends			Butt weld ends			
	1/2	3/4	1	1/2	3/4	1	1/2	3/4	1	
NPS										
Face-to-face acc. to data sheet resp. customer request										
L	(mm)	210	210	230	150	150	230	160	160	160
Dimensions Standard-flange dimensions refer to page 12.										
H	(mm)	100	100	100	100	100	100	100	100	100
S	(mm)	70	70	70	70	70	70	70	70	70
HEX	(mm)	50	50	50	50	50	50	50	50	50
Weights										
(approx.)	(kg)	5,6	6,1	6,6	4,1	4	6,6	4,1	4	3,9

Parts				
Pos.	Sp.p.	Description	Fig. 42./45.60A	Fig. 52./55.60A
1		Body	SA105	SA182F321
1.8	x	Assembly stop valve, cpl.	AISI303	
2	x	Strainer	SA240Gr.304	
6		Cap	SA105	SA182F321
24	x	Controller, cpl.	TB 102 / 85 (corrosion resistant bimetal)	
49	x	Sealing ring	SA182F321	
50	x	Screw plug (M14x1,5)	SA182F321	
51	x	Drain valve	AISI303	
56	x	Ball valve for blow down	SA351CF8M	
		L Spare parts		

Information / restriction of technical rules need to be observed!
 Operating and installation instructions can be downloaded at www.ari-armaturen.com.
 Resistance and fitness must be verified (or contact the manufacturer for information).

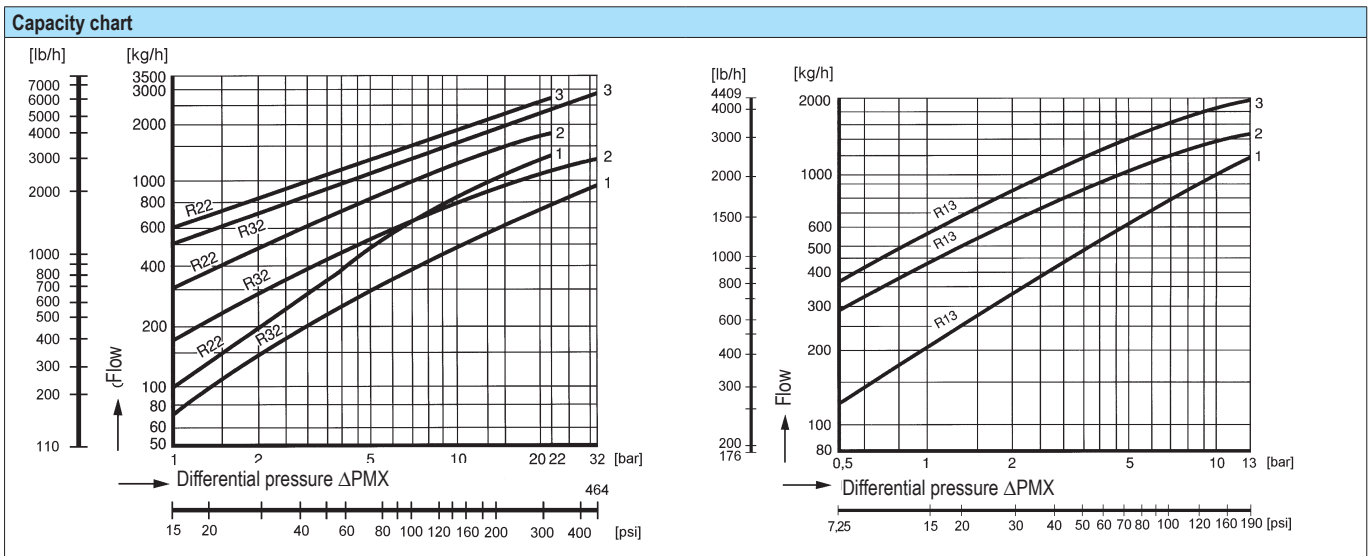

The capacity chart shows the maximum capacity at factory setting..
Curve 1: Maximum flow of hot condensate at approx. 10 K below saturation temperature.
Curve 2: Maximum flow of sub-cooled condensate at approx. 30 K below saturation temperature (with back-up of condensate).
Curve 3: Maximum flow quantity of cold condensate at about 20°C (during start-up of a cold installation).
 The condensate temperature determines the opening of the controller. Capacity is increased with the sub-cooling temperature of the condensate.

Options		
 Drain valve	 Ball valve for blow down (restricted to 16 bar, 210°C)	 Stop valve with bellows seal

CONA[®]M All-in-one - Thermostatic steam trap with integrated inlet and outlet valves
 (Forged steel, Stainless steel)

Fig. 61A....1 with flanges

 Fig. 61A....2
 with screwed sockets

 Fig. 61A....3
 with socket weld ends

 Fig. 61A....4
 with butt weld ends

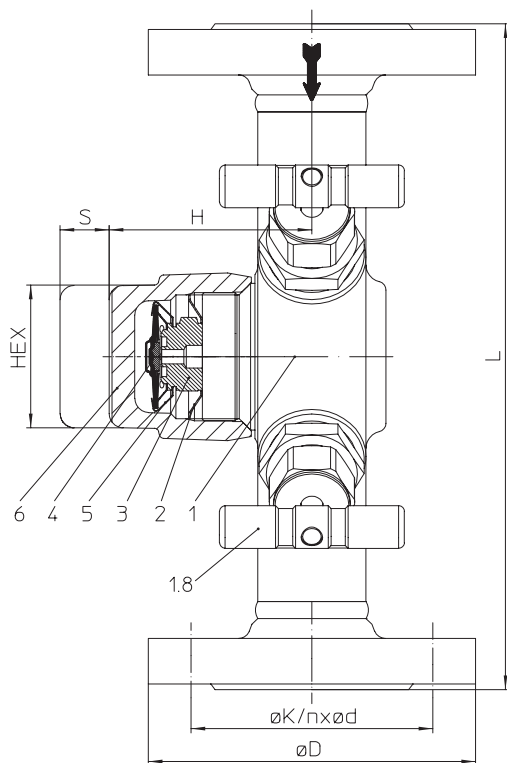
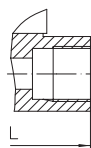
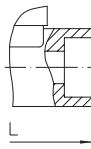
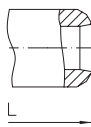
Pressure-Temperature-Diagramm

Figure	Nominal pressure	Material	NPS	Operating pressure PS	Inlet temperature TS	allowable differential pressure ΔPMX	for controller
42.61A	ANSI150	SA105	1/2" - 1"	13 barg	225 °C	32 bar	R32
				5,5 barg	427 °C		
45.61A	ANSI300	SA105	1/2" - 1"	32 barg	411 °C		
				28 barg	427 °C		
52.61A	ANSI150	SA182F321	1/2" - 1"	13 barg	225 °C		
				2,4 barg	510 °C		
55.61A	ANSI300	SA182F321	1/2" - 1"	32 barg	350 °C		
				27 barg	510 °C		

 DIN/EN-Constructions refer to data sheet CONA[®]All-in-one

Types of connection

Other types of connection on request.

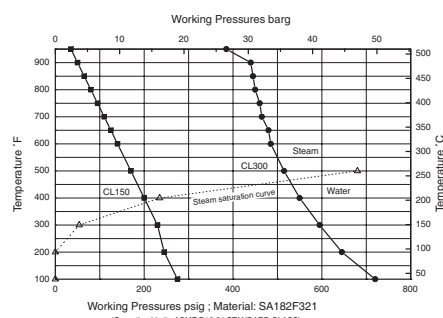
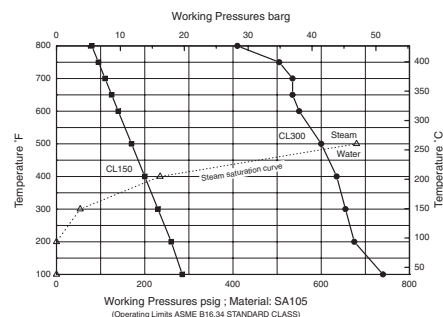
- Flanges1 _____ acc. to ASME B16.5
- Screwed sockets2 _____ NPT thread acc. to ANSI B1.20.1 or Rp thread acc. to DIN EN 10226-1
- Socket weld ends3 _____ acc. to ASME B16.11
- Butt weld ends4 _____ ASME B16.25 (Note restriction on operating pressure / inlet temperature depending to design!)

Features

- Thermostatic steam trap with noncorrosive and robust water hammer proofed capsule
- Mounting position senkrecht or waagrecht
- User-friendly handling, easy and quick access to the controller
- Non return protection
- With inside strainer
- Filter effect maximised at horizontal installation
- Optimized design for quick installation
- Maintenance simplified due to screwed cap without sealing
- The controller maybe changed without disturbing the pipe work

Capsule:

(chooseable for operating range)

- Capsule No. 1 _____ for condensate discharge at boiling temperature (only on request)
- Capsule No. 2 _____ for condensate sub-cooling about approx. 10 K (Standard)
- Capsule No. 3 _____ for condensate sub-cooling about approx. 30 K

Options

(Design refer to page 5)

- Drain valve (Pos. 51)
- Ball valve for blow down (Pos. 56)
- Stop valve with bellows seal (Pos. 8)

Types of connection	Flanges			Screwed sockets Socket weld ends			Butt weld ends			
	1/2	3/4	1	1/2	3/4	1	1/2	3/4	1	
NPS										
Face-to-face acc. to data sheet resp. customer request										
L	(mm)	210	210	230	150	150	230	160	160	160
Dimensions Standard-flange dimensions refer to page 12.										
H	(mm)	70	70	70	70	70	70	70	70	70
S	(mm)	40	40	40	40	40	40	40	40	40
HEX	(mm)	50	50	50	50	50	50	50	50	50
Weights										
(approx.)	(kg)	4,8	5,3	5,8	3,3	3,2	5,8	3,4	3,3	3,2

Parts				
Pos.	Sp.p.	Description	Fig. 42./45.61A	Fig. 52./55.61A
1		Body	SA105	SA182F321
1.8	x	Assembly stop valve, cpl.	AISI303	
2	x	Strainer	SA240Gr.304	
3	x	Seat	AISI303	
4	x	Capsule (Diaphragm / Capsule)	Hastelloy / SA240Gr.304	
5	x	Spring actuated clip	AISI301	
6		Cap	SA105	SA182F321
49	x	Sealing ring	SA182F321	
50	x	Screw plug (M14x1,5)	SA182F321	
51	x	Drain valve	AISI303	
56	x	Ball valve for blow down	SA351CF8M	
57		Non return protection	SA240Gr.304	
L Spare parts				

Information / restriction of technical rules need to be observed!

Operating and installation instructions can be downloaded at www.ari-armaturen.com.

Resistance and fitness must be verified (or contact the manufacturer for information).

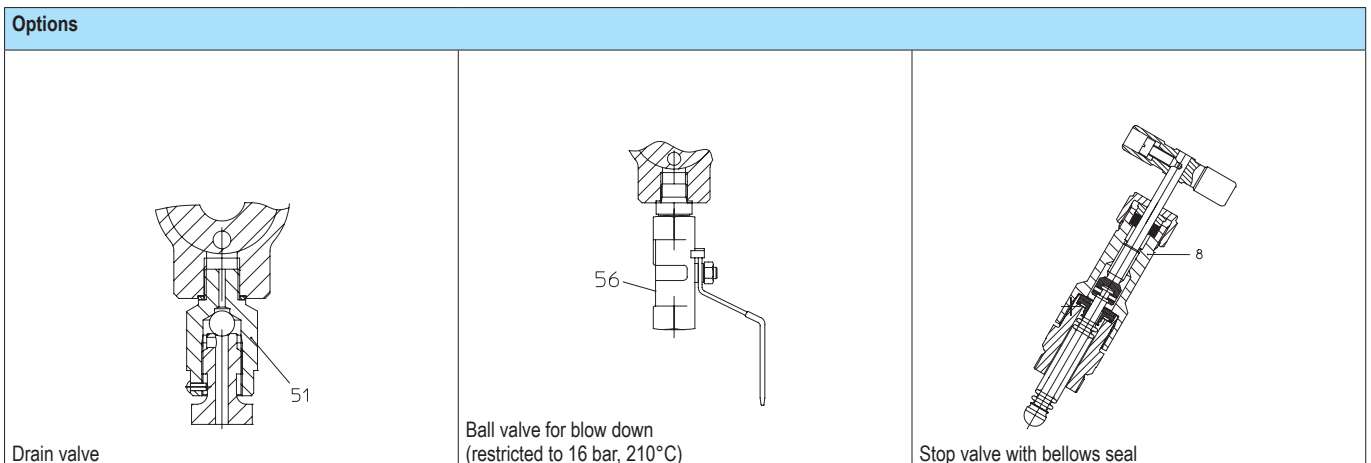
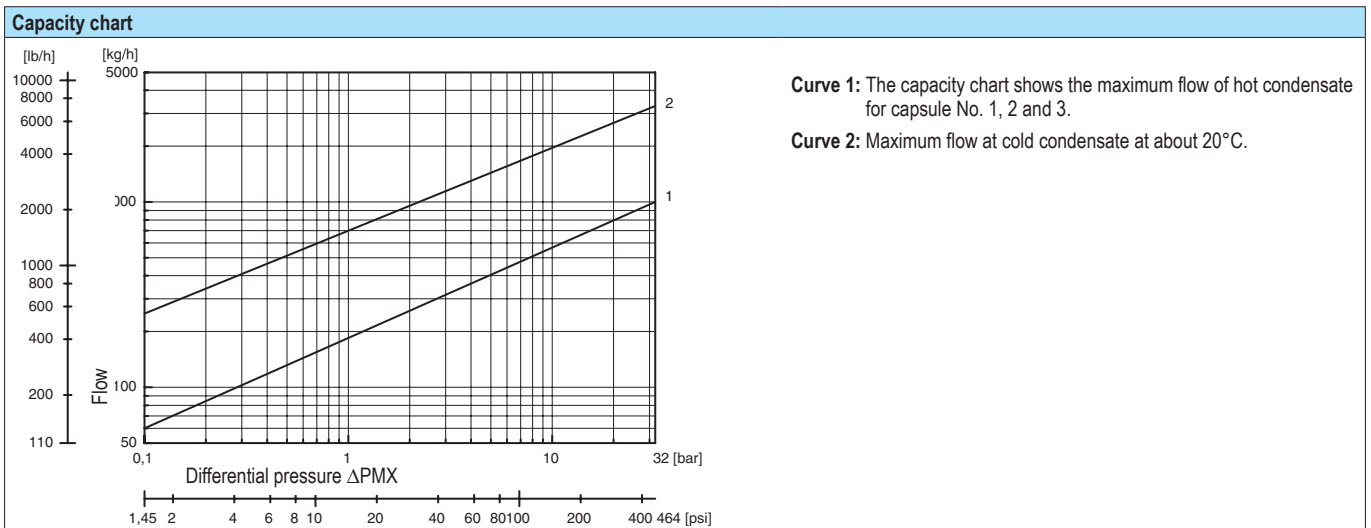

CONA®TD All-in-one - Thermodynamic steam trap with integrated inlet and outlet valves
(Forged steel, Stainless steel)

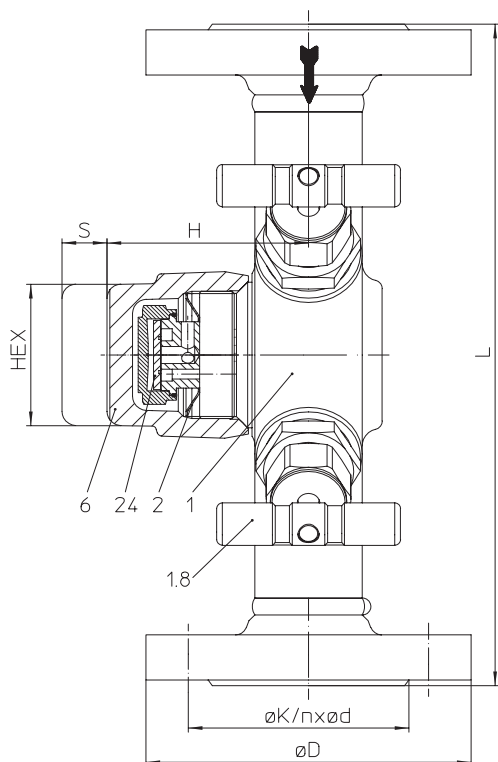

Fig. 64A....1 with flanges

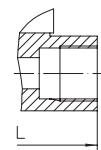

Fig. 64A....2
with screwed sockets

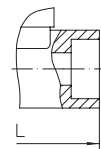

Fig. 64A....3
with socket weld ends

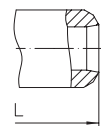

Fig. 64A....4
with butt weld ends

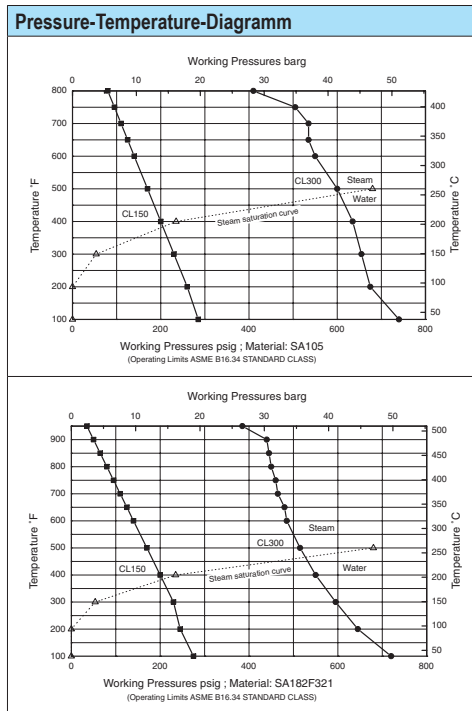

Figure	Nominal pressure	Material	NPS	Operating pressure PS	Inlet temperature TS	allowable differential pressure ΔPMX	permissible pressure ratio
42.64A	ANSI150	SA105	1/2" - 1"	13 barg	225 °C	32 bar	Back pressure / Inlet pressure: ≤ 0,8 barg
				5,5 barg	427 °C		
45.64A	ANSI300	SA105	1/2" - 1"	32 barg	411 °C		
				28 barg	427 °C		
52.64A	ANSI150	SA182F321	1/2" - 1"	13 barg	225 °C		
				2,4 barg	510 °C		
55.64A	ANSI300	SA182F321	1/2" - 1"	32 barg	377 °C		
				27 barg	510 °C		

DIN/EN-Constructions refer to data sheet CONA®All-in-one

Types of connection Other types of connection on request.

- Flanges1 _____ acc. to ASME B16.5
- Screwed sockets2 _____ NPT thread acc. to ANSI B1.20.1 or Rp thread acc. to DIN EN 10226-1
- Socket weld ends3 _____ acc. to ASME B16.11
- Butt weld ends4 _____ ASME B16.25 (Note restriction on operating pressure / inlet temperature depending to design!)

Features

- Thermodynamic steam trap with replaceable controller-unit and cap with heat chamber wich minimize the effects from the weather conditions to the function of the trap such as low ambient temperatures, rain, wind, etc..
- Mounting position senkrecht or waagrecht
- User-friendly handling, easy and quick access to the controller
- Intermittent mode of operation
- Heat chamber minimizes the impact of weather conditions on the trap's performance
- Robust and resistant to water-hammer
- Integrated non return protection
- With inside strainer
- Optimized design for quick installation
- Maintenance simplified due to screwed cap without sealing
- The controller maybe changed without disturbing the pipe work

Options (Design refer to page 7)

- Drain valve (Pos. 51)
- Ball valve for blow down (Pos. 56)
- Stop valve with bellows seal (Pos. 8)

Types of connection	Flanges			Screwed sockets Socket weld ends			Butt weld ends			
	1/2	3/4	1	1/2	3/4	1	1/2	3/4	1	
NPS										
Face-to-face acc. to data sheet resp. customer request										
L	(mm)	210	210	230	150	150	230	160	160	160
Dimensions Standard-flange dimensions refer to page 12.										
H	(mm)	70	70	70	70	70	70	70	70	70
S	(mm)	40	40	40	40	40	40	40	40	40
HEX	(mm)	50	50	50	50	50	50	50	50	50
Weights										
(approx.)	(kg)	4,8	5,3	5,8	3,3	3,2	5,8	3,4	3,3	3,2

Parts				
Pos.	Sp.p.	Description	Fig. 42./45.64A	Fig. 52./55.64A
1		Body	SA105	SA182F321
1.8	x	Assembly stop valve, cpl.	AISI303	
2	x	Strainer	SA240Gr.304	
6		Cap	SA105	SA182F321
24	x	Controller, cpl.	AISI440	
49	x	Sealing ring	SA182F321	
50	x	Screw plug (M14x1,5)	SA182F321	
51	x	Drain valve	AISI303	
56	x	Ball valve for blow down	SA351CF8M	
L Spare parts				

Information / restriction of technical rules need to be observed!
 Operating and installation instructions can be downloaded at www.ari-armaturen.com.
 Resistance and fitness must be verified (or contact the manufacturer for information).

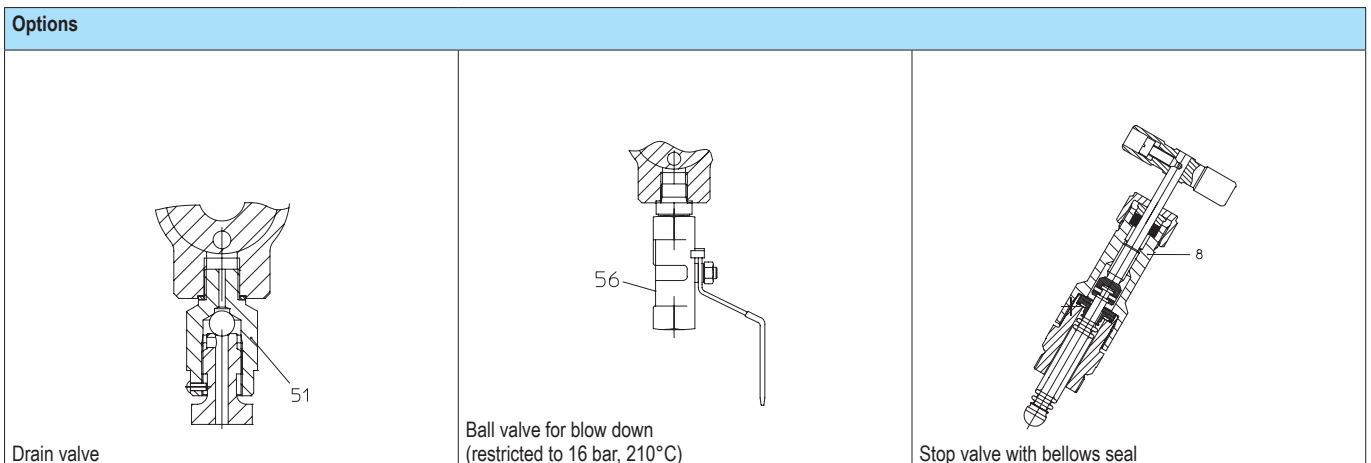
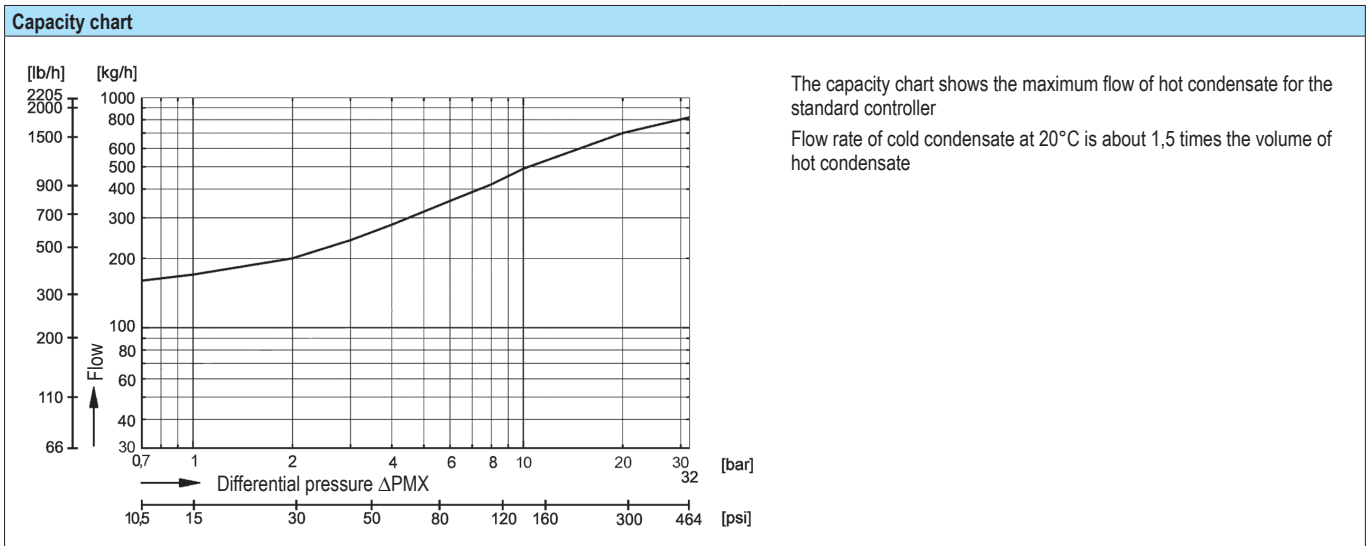

Handvalve for inlet and outlet (Forged steel, Stainless steel)

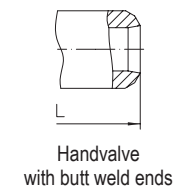
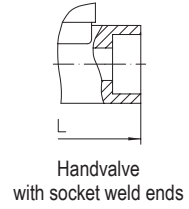
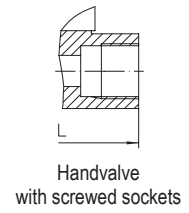
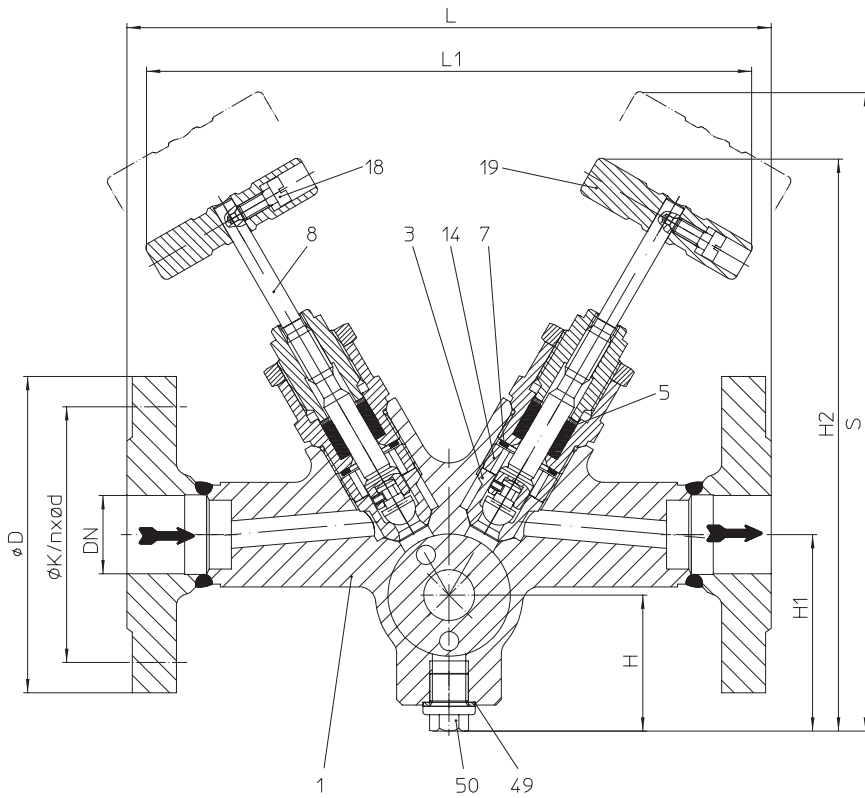

Stop valve with gland packing

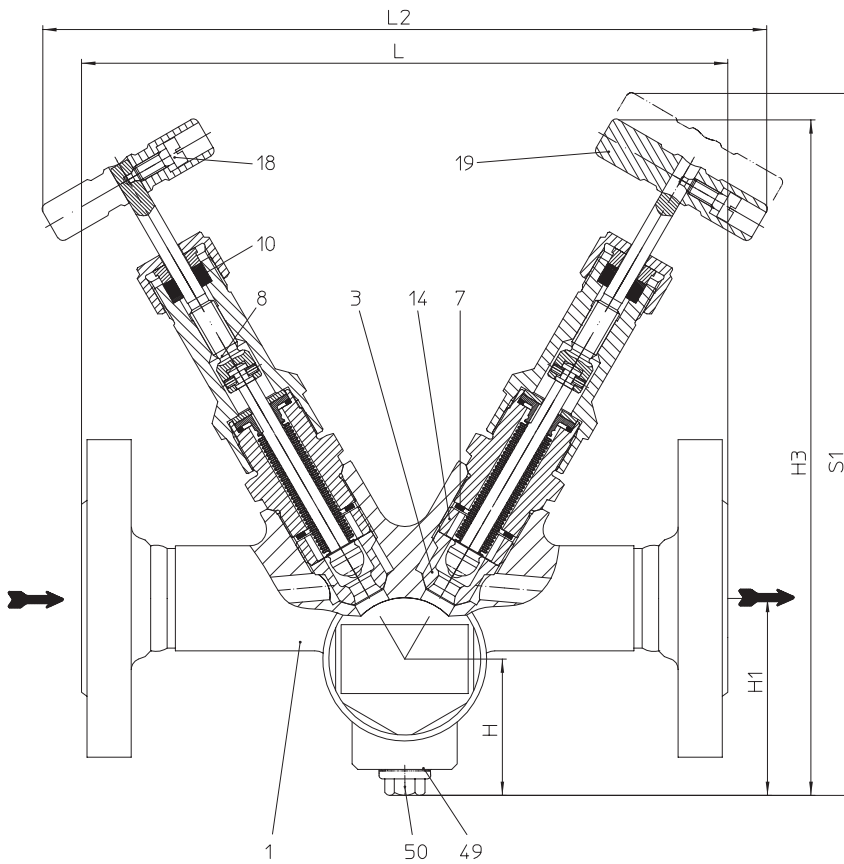

Stop valve with bellows seal

Options

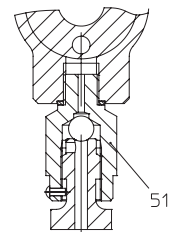

Drain valve

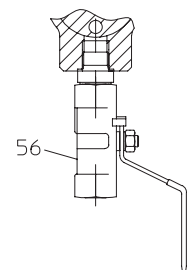

Ball valve for blow down (restricted to 16 bar, 210°C)

Types of connection	Flanges			Screwed sockets Socket weld ends			Butt weld ends		
	1/2	3/4	1	1/2	3/4	1	1/2	3/4	1
NPS									

Face-to-face acc. to data sheet resp. customer request										
L	(mm)	210	210	230	150	150	230	160	160	160

Dimensions											Standard-flange dimensions refer to page 12.
L1	(mm)	220	220	220	220	220	220	220	220	220	220
L2 (Bellows seal)	(mm)	259	259	259	259	259	259	259	259	259	259
H	(mm)	50	50	50	50	50	50	50	50	50	50
H1	(mm)	72	72	72	72	72	72	72	72	72	72
H2	(mm)	208	208	208	208	208	208	208	208	208	208
H3 (Bellows seal)	(mm)	241	241	241	241	241	241	241	241	241	241
S	(mm)	217	217	217	217	217	217	217	217	217	217
S1 (Bellows seal)	(mm)	250	250	250	250	250	250	250	250	250	250

Parts				
Pos.	Sp.p.	Description	Forged steel	Stainless steel
1.1		Body	SA105	SA182F321
1.3	x	Seat	AISI303	
1.5	x	Packing ring	Pure graphite	
1.7		Sealing ring	Graphite	
1.8	x	Bonnet Handvalve,	AISI303	
1.10	x	Packing ring	Pure graphite	
1.14		Banjo bolt	AISI303	
1.18	x	Cheese head screw	A2-70	
1.19	x	Hand grip	AISI430F	
1.49	x	Sealing ring	SA182F321	
1.50	x	Screw plug (M14x1,5)	SA182F321	
1.51	x	Drain valve (M14x1,5)	AISI303	
1.56	x	Ball valve for blow down	SA351CF8M	
L Spare parts				

Information / restriction of technical rules need to be observed!
 Operating and installation instructions can be downloaded at www.ari-armaturen.com.
 Resistance and fitness must be verified (or contact the manufacturer for information).

Combinations		
CONA®TD All-in-one	CONA®M All-in-one	CONA®B All-in-one
<p>Stop valve with gland packing (with flanges, Screwed sockets, Socket weld ends, Butt weld ends)</p> <p>Options Stop valve with bellows seal</p>		

CONA®SC All-in-one - Ball float steam trap with integrated inlet and outlet valves
(Forged steel, Stainless steel)

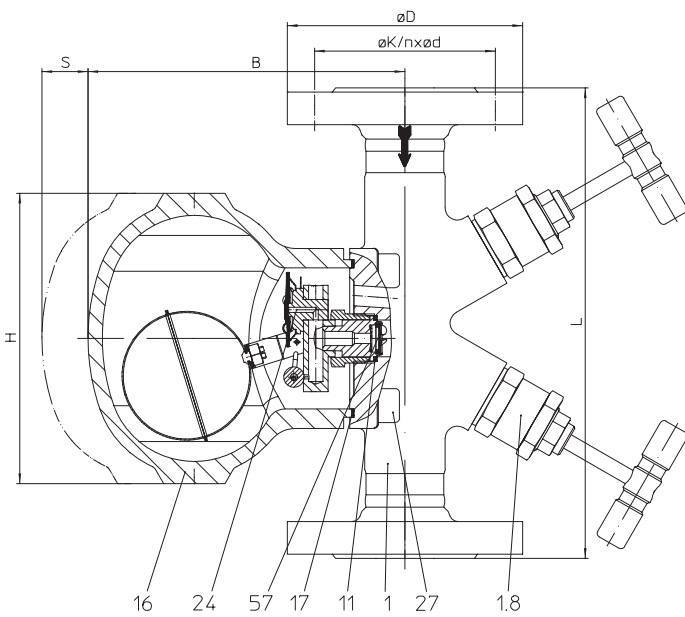

Fig. 63A...1 with flanges

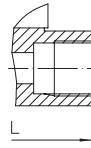

Fig. 63A...2 with screwed sockets

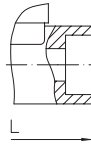

Fig. 63A...3 with socket weld ends

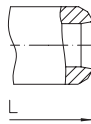

Fig. 63A...4 with butt weld ends

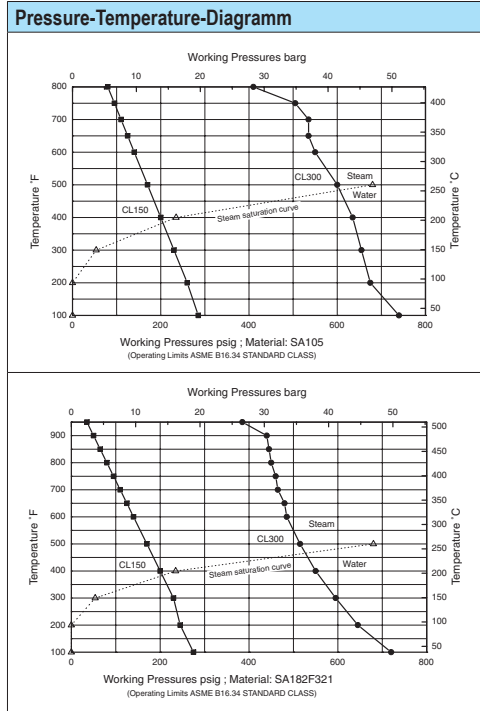

Figure	Nominal pressure	Material	NPS	Operating pressure PS	Inlet temperature TS	allowable differential pressure ΔPMX	for controller
42.63A	ANSI150	Hood: SA216WCB	1/2" - 1"	4 barg	467 °C	32 bar	R32
				5,5 barg	427 °C		
				14 barg	199 °C		
45.63A	ANSI300	Hood: SA216WCB	1/2" - 1"	21 barg	427 °C	21 bar	R21
				32 barg	411 °C	14 bar	R14
52.63A	ANSI150	Hood: SA351CF8	1/2" - 1"	2,4 barg	510 °C	4 bar	R4
				4 barg	467 °C		
				12,8 barg	218 °C		
55.63A	ANSI300	Hood: SA351CF8	1/2" - 1"	21 barg	510 °C		
				32 barg	262 °C		

DIN/EN-Constructions refer to data sheet CONA®All-in-one

Types of connection

Other types of connection on request.

- Flanges1 _____ acc. to ASME B16.5
- Screwed sockets2 _____ NPT thread acc. to ANSI B1.20.1 or Rp thread acc. to DIN EN 10226-1
- Socket weld ends3 _____ acc. to ASME B16.11
- Butt weld ends4 _____ ASME B16.25 (Note restriction on operating pressure / inlet temperature depending to design!)

Features

- Ball float steam trap with level control for the condensate-discharge from all kinds of steam systems
- Rapid system start-up due to thermostatic air venting capsule
- User-friendly handling, easy and quick access to the controller
- Immediate discharge of hot boiling condensat
- Discharge of great condensate quantities even at low differential pressure
- Body with flanged hood
- With inside strainer
- Non return protection
- The controller maybe changed without disturbing the pipe work

Mounting position:

- Standard: vertical
- Optional: horizontal with inlet from right or left

Please indicate when ordering!
Installation position may be changed on-site (see operating instructions).

Options (Design refer to page 3)

- Vent plug (Pos. 47)
- Plug (Pos. 50)
- Manual air vent valve (Pos. 51)
- Ball valve for blow down (Pos. 56)
- Stop valve with bellows seal

Parts				
Pos.	Sp.p.	Description	Fig. 42./45.63A	Fig. 52./55.63A
1		Body	SA105	SA182F321
1.8	x	Assembly stop valve, cpl.	AISI303	
11	x	Sealing ring	A4	SA182F321
16		Hood	SA216WCB	SA351CF8
17	x	Gasket	GRAPHIT (CrNi laminated with graphite)	
24	x	Controller, cpl. / Capsule	SA240Gr.304 / Hastelloy	
27		Cheese head screw	SA193Gr.B16	
47		Vent plug (M14x1,5)	SA182F321	
49	x	Sealing ring	A4	SA182F321
50	x	Screw plug (M14x1,5)	SA182F321	
51	x	Drain valve *	AISI303	
56	x	Ball valve for blow down	SA351CF8M	
57	x	Non return protection	SA240Gr.304	
L Spare parts				

Information / restriction of technical rules need to be observed!

Operating and installation instructions can be downloaded at www.ari-armaturen.com.

Resistance and fitness must be verified (or contact the manufacturer for information).

Types of connection	Flanges			Screwed sockets Socket weld ends			Butt weld ends			
	1/2	3/4	1	1/2	3/4	1	1/2	3/4	1	
NPS										
Face-to-face acc. to data sheet resp. customer request										
L	(mm)	210	210	230	150	150	230	160	160	160
Dimensions Standard-flange dimensions refer to page 12.										
H	(mm)	150	150	150	150	150	150	150	150	150
B	(mm)	156	156	156	156	156	156	156	156	156
S	(mm)	112	112	112	112	112	112	112	112	112
Weights										
(approx.)	(kg)	7	7,7	8,2	5,6	5,5	8,2	5,5	5,4	5,3

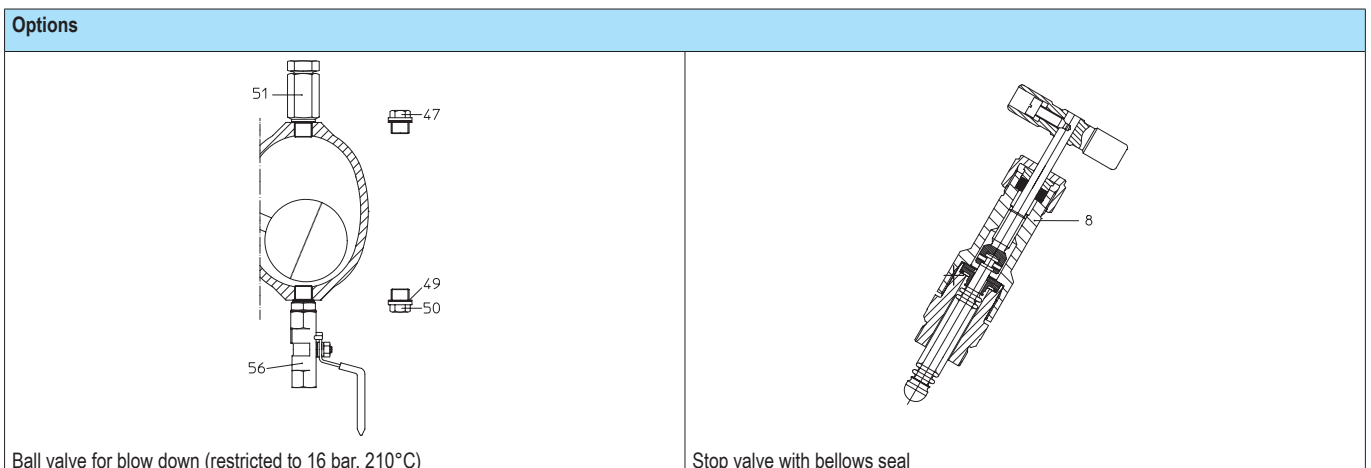
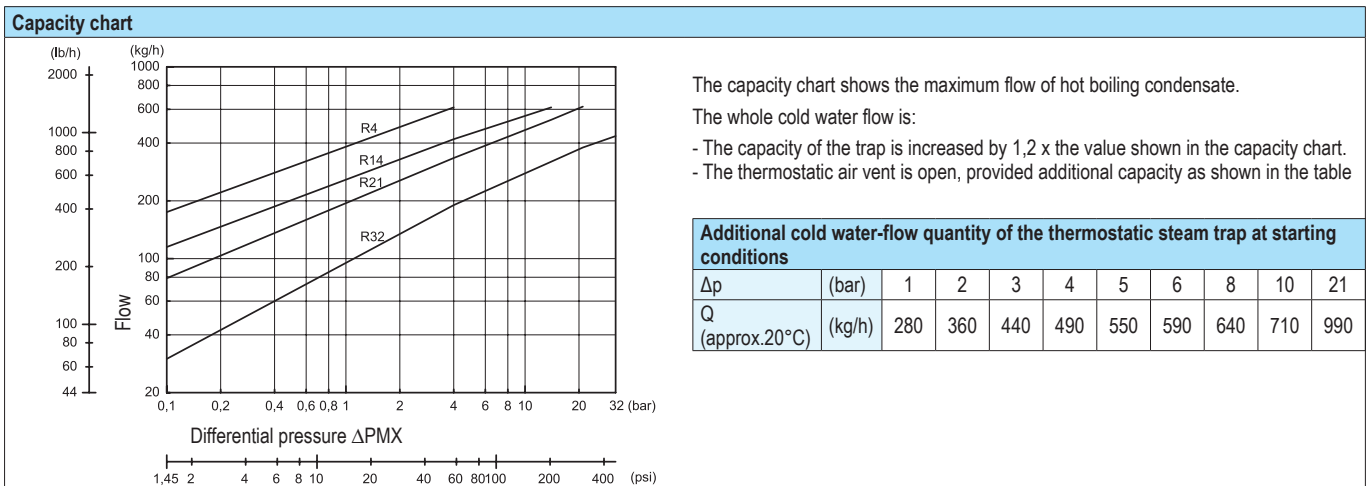

Informations about pipe welding
Welding groove acc. to DIN 2559

The material used for ARI valves with butt weld ends are: SA105

Note: SA182F321

Note restriction on operating pressure / inlet temperature depending to design!

Due to our experience, we recommend to apply an electric welding process.

Because of the different material compositions and wall thickness of the steam traps and the pipe gas welding shall not be applied. Quenching cracks and coarse grain structure may develop.

Steam traps with socket-weld ends shall only be welded by arc welding (welding process 111 acc. to DIN EN 24063).

If during the time of warranty others than the manufacturer or by the manufacturer authorized persons are interfering in the product and/or the setting, the right of claim for warranty will lapse!

Standard-flange dimensions acc. to ASME B16.5

NPS			1/2	3/4	1
ANSI150	ØD	(mm)	89	99	108
	ØK	(mm)	60	70	79
	n x Ød	(mm)	4 x 16	4 x 16	4 x 16
ANSI300	ØD	(mm)	95	117	124
	ØK	(mm)	66,5	82,5	89
	n x Ød	(mm)	4 x 16	4 x 19	4 x 19