

Pressure reducing valve in straightway form  
DN 15 - 150

**ARI-PREDU®**  
Pressure regulating valve, straight  
through with diaphragm actuator DMA

- Actuator with rolling diaphragm

Grey cast iron  
SG iron  
Cast steel

**Fig. 701**

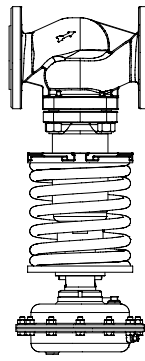

Page 2

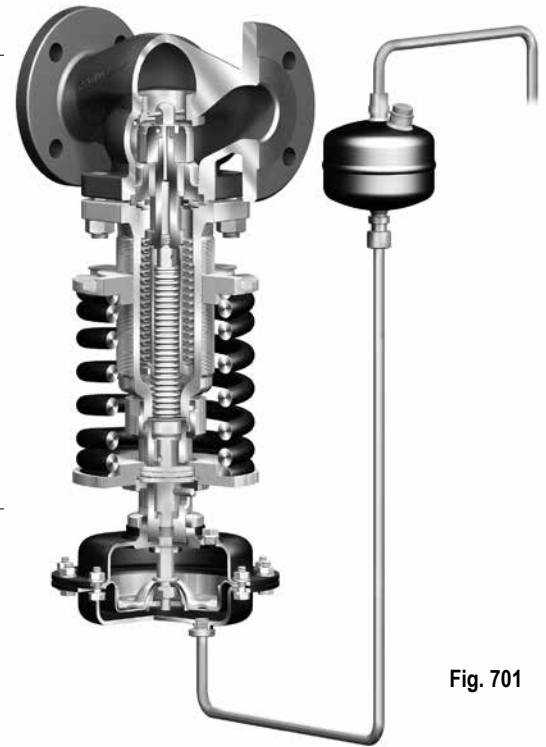

**Fig. 701**

**Features:**

- Compact design
- Construction without pillars
- Exact and easy adjustment
- Diameter independent ranges
- Simple change of spring and actuator
- 5 exchangeable actuator sizes
- 3 exchangeable spring sizes
- Pressure balanced by stainless steel bellow
- Spindle sealing via stainless steel bellow
- Secondary stem sealing (optional)
- Tapered seat ring
- Screwed seat ring
- Kvs-values reduceable
- Flow divider for noise reduction (optional)
- Plug with PTFE soft seal (optional)

Pressure regulating valve, straight through with diaphragm actuator DMA

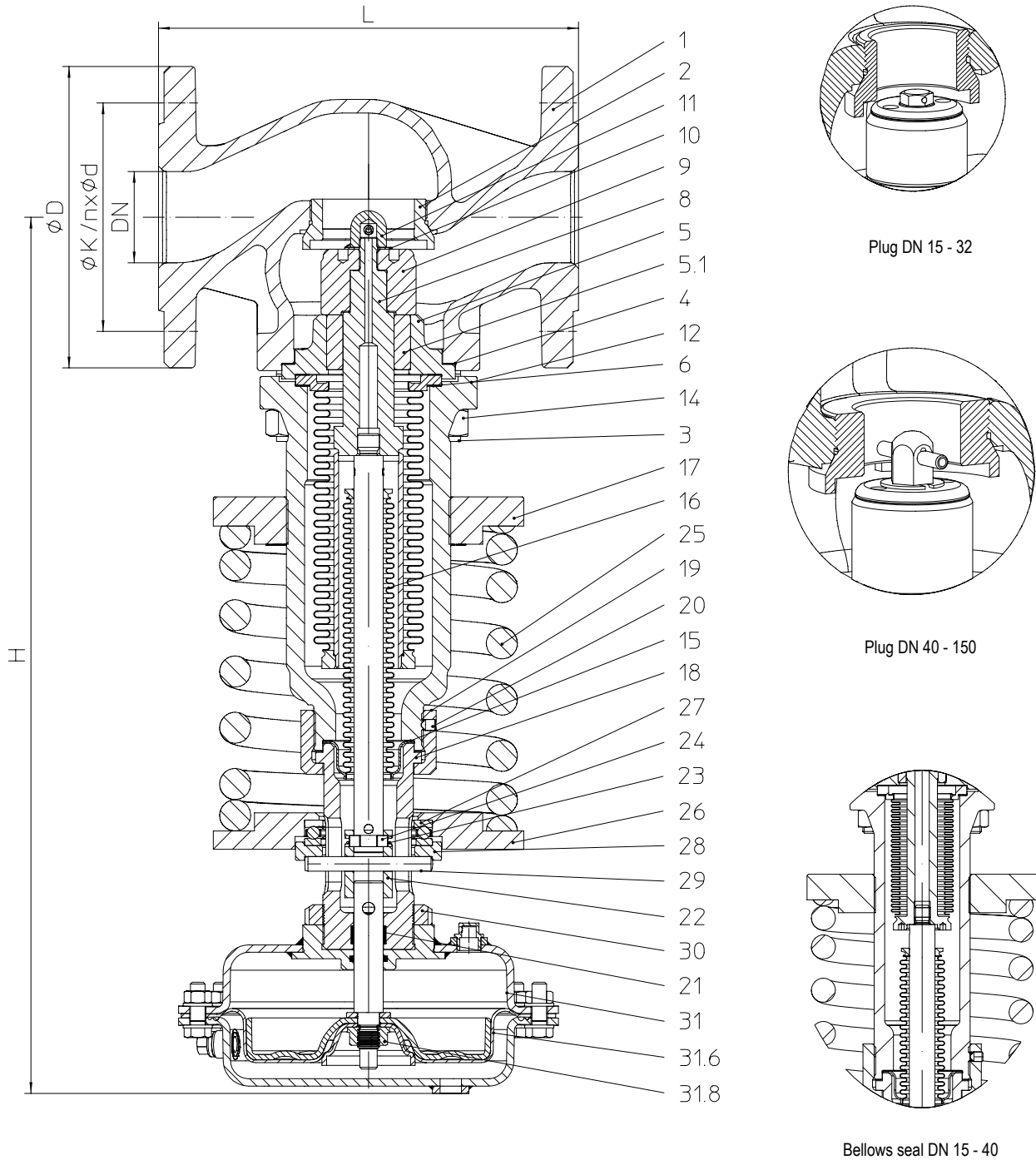

Figure	Nominal pressure	Material	Nominal diameter	Downstream-pressure ranges	Actuator
12.701	PN16	EN-JL1040	DN15-150	0,2 - 16 barg	DMA 400
22.701	PN16	EN-JS1049	DN15-150		DMA 250
23.701	PN25	EN-JS1049	DN15-150		DMA 160
34.701	PN25	1.0619+N	DN15-150		DMA 80
35.701	PN40	1.0619+N	DN15-150		DMA 40

Technical data of the actuator refer to page 6.

DN	15	20	25	32	40	50	65	80	100	125	150		
<b>Kvs-value</b>													
Kvs-value	standard	(m³/h)	3,2	5	8	12,5	20	32	50	80	125	190	280
	reduced	(m³/h)	0,1 / 0,4 / 1 / 2,5	0,1 / 0,4 / 1 / 2,5 / 4	0,1 / 0,4 / 1 / 2,5 / 4 / 6,3	--	--	--	--	--	--	--	--
Seat-ø	(mm)	18	22	25	32	40	50	65	80	100	125	150	
Travel	(mm)	4	5	6	8	8	10	11	13	16	19	22	
Max. differential pressure drop	(bar)	40	40	25	25	25	25	20	20	20	16	16	
Shut off class	Leakage class I acc. to DIN EN 1349 or DIN EN 60534-4 ( ≤ 0,05% from Kvs-value)												

Face-to-face dimension FTF series 1 according to DIN EN 558												
L	(mm)	130	150	160	180	200	230	290	310	350	400	480

Flanges acc. to DIN EN 1092-1/-2			Flange holes / -thickness tolerances acc. to DIN 2533/2544/2545										
ØD	PN16	(mm)	95	105	115	140	150	165	185	200	220	250	285
	PN25 / 40	(mm)	95	105	115	140	150	165	185	200	235	270	300
ØK	PN16	(mm)	65	75	85	100	110	125	145	160	180	210	240
	PN25 / 40	(mm)	65	75	85	100	110	125	145	160	190	220	250
n x Ød	PN16	(mm)	4 x 14	4 x 14	4 x 14	4 x 18	4 x 18	4 x 18	4 x 18	8 x 18	8 x 18	8 x 18	8 x 22
	PN25 / 40	(mm)	4 x 14	4 x 14	4 x 14	4 x 18	4 x 18	4 x 18	8 x 18	8 x 18	8 x 22	8 x 26	8 x 26

Dimensions													
H	DMA 400	(mm)	495	495	500	500	540	540	545	585	610	650	690
	DMA 250	(mm)	455	455	460	460	500	500	505	545	585	610	650
	DMA 160	(mm)	440	440	440	440	480	480	490	530	550	590	630
	DMA 80	(mm)	435	435	440	440	480	480	485	530	550	590	630
	DMA 40	(mm)	435	435	440	440	480	480	485	530	550	590	630

Weights													
12.701 / 22./23.701 / 34./35.701	with DMA 400	(kg)	26	27	28	30	35	41	48	70	85	125	158
	with DMA 250	(kg)	21	22	23	25	30	36	43	65	83	123	156
	with DMA 160	(kg)	19	20	21	23	28	34	41	63	81	121	154
	with DMA 80	(kg)	18	19	20	22	27	33	40	62	80	120	153
	with DMA 40	(kg)	17	18	19	21	26	32	39	61	79	119	152

Downstream-pressure ranges							
	(barg)	0,2 - 0,6	0,5 - 1,2	0,8 - 2,5	2 - 5	4,5 - 10	8 - 16
Pneumatic Actuator DMA	(cm²)	DMA 400	DMA 250	DMA 160	DMA 80	DMA 40	
Pneumatic Actuator PN-max.	(barg)	1,6	2,5	6	10	20	
Spring end-No.		04	04	07	07	07	10

DN	15	20	25	32	40	50	65	80	100	125	150
----	----	----	----	----	----	----	----	----	-----	-----	-----

Proportional ranges (Combination: actuator with valve in ± bar)														
Pneumatic Actuator (cm²)	Downstream pressure range (barg)	DMA 400	0,2 - 0,6	0,05	0,05	0,05	0,05	0,05	0,06	0,07	0,08	0,08	0,10	0,15
		DMA 250	0,5 - 1,2	0,09	0,09	0,06	0,08	0,09	0,09	0,10	0,15	0,10	0,15	0,23
		DMA 160	0,8 - 2,5	0,15	0,20	0,15	0,20	0,20	0,25	0,25	0,30	0,35	0,40	0,50
		DMA 80	2,0 - 5,0	0,40	0,45	0,40	0,45	0,35	0,40	0,45	0,50	0,60	0,75	0,90
		DMA 40	4,5 - 10,0	0,55	0,55	0,60	0,65	0,70	0,75	0,80	0,85	0,90	1,20	1,35
		DMA 40	8,0 - 16,0	0,80	0,85	1,00	1,05	1,10	1,25	1,30	1,50	1,75	1,80	2,00

Pressure reducing valves are proportional regulators with permanent control deviation depending from the construction.

The actual control deviation depends on the valve load.

$$(Kv\text{-value} / Kvs\text{-value-max}) \times \text{Proportional range} = \text{Actual control deviation}$$

The values shown are preliminary values and may vary by the real plant

Pressure-temperature-ratings		Intermediate values for max. permissible operational pressures can be determined by linear interpolation of the given temperature / pressure chart.									
------------------------------	--	-----------------------------------------------------------------------------------------------------------------------------------------------------	--	--	--	--	--	--	--	--	--

acc. to DIN EN 1092-2			-60°C to <-10°C*	-10°C to 120°C	150°C	200°C	250°C	300°C	350°C
EN-JL1040	PN16	(bar)	--	16	14,4	12,8	11,2	9,6	--
EN-JS1049	PN16	(bar)	on request	16	15,5	14,7	13,9	12,8	11,2
EN-JS1049	PN25	(bar)	on request	25	24,3	23	21,8	20	17,5

acc. to manufacturers standard			-60°C to <-10°C*	-10°C to 120°C	150°C	200°C	250°C	300°C	350°C
1.0619+N	PN25	(bar)	18,7	25	23,9	22	20	17,2	16
1.0619+N	PN40	(bar)	30	40	38,1	35	32	28	25,7

\* Studs and nuts made of A4-70 (at temperatures below -10°C)

**Application**

The pressure regulating valve is a direct acting proportional regulator, self operated; which regulates a high inlet pressure to a smaller downstream pressure. The downstream pressure is regulated, this means the valve closes when the downstream pressure rises.

Operating fields are to regulate fluids of the group II acc. to Pressure Equipment Directive 2014/68/EU, e.g. steam, neutral gases, vapours and liquids. With steam and liquids, having temperatures higher than the allowable working temperatures a water seal pot must be installed in the control line (to protect actuator diaphragm) (refer to page 6).

Installation in the control line can be seen in the system drawing:

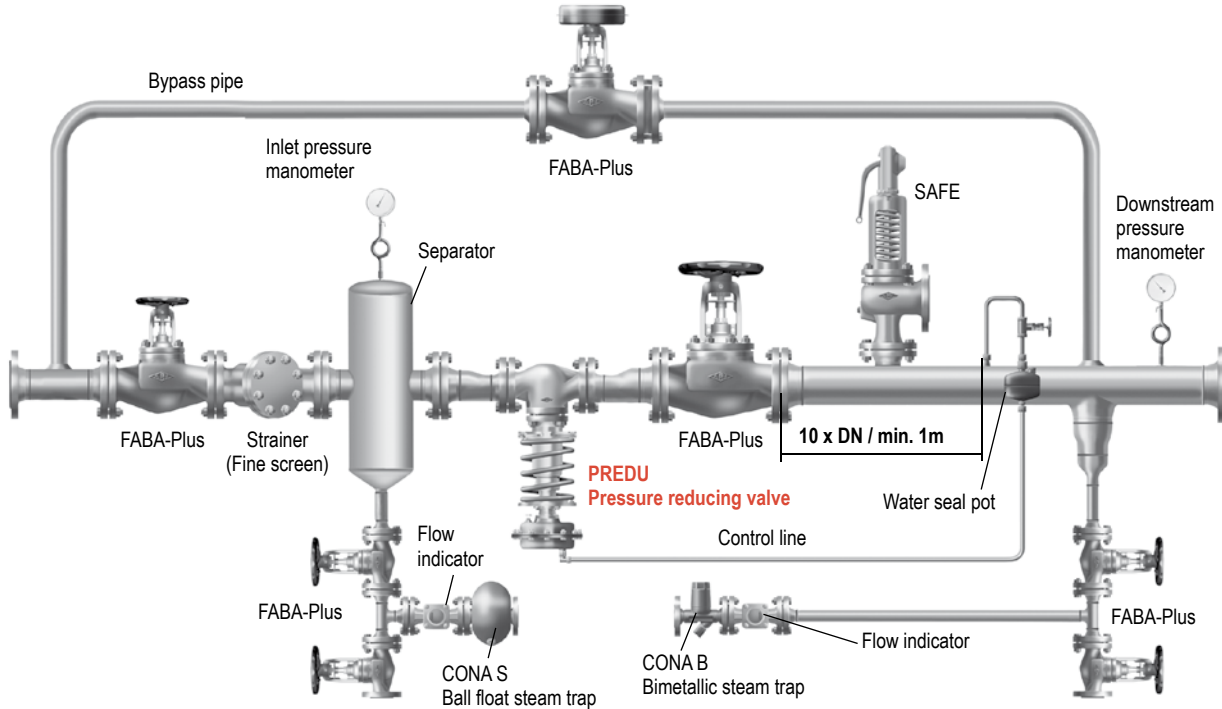

**Sizing**

For the calculation you have the program myValve (Program part „Pressure reducing valves“). After giving in the process data, the Fig.-No. and size is recommended out of the integrated data bank. The diameter of the piping in front and behind of the pressure regulating valve can also be calculated with the max. allowable flow velocities with myValve.

The necessary downstream pressure gives the needed pressure range. Because the regulation tolerance at the end of the range is smaller, the smaller range must be used, in case of a range overlapping. For example: Downstream pressure 2,4 bar(g), choose actuator range 0,8 - 2,5 bar(g), although 2-5 bar(g) could be used.

The safety valve used to secure the downstream pressure must have an adequate distance between set pressure and downstream pressure. The max. possible capacity of the pressure reducing valve is used to select the safety valve at it's set pressure. The max. possible capacity has to be calculated with  $p_1$  (= max. possible inlet pressure),  $p_2$  (= set pressure of the safety valve) and the  $Kvs$ -value of the pressure reducing valve with myValve. With this found capacity you can, with myValve (Program part: Safety valves), select the safety valve, and with the pressure reducing valves and other valves, administer them under a project.

**Important:** If not secured that the bypass valve has a larger capacity than the pressure reducing valve, or that it can be open parallel, then the extra capacity must be considered for the safety valve sizing.

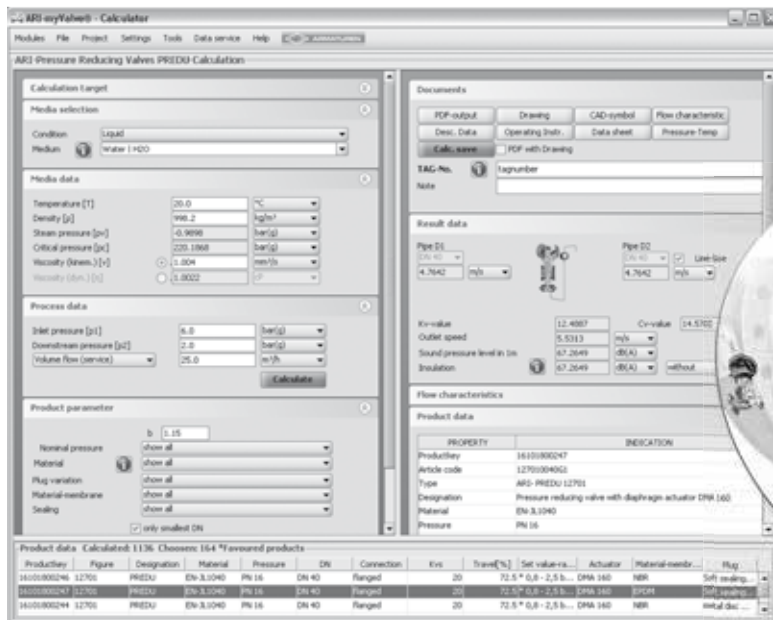

Parts					
Pos.	Ers.	Description	Fig. 12.701	Fig. 22.701 Fig. 23.701	Fig. 34.701 Fig. 35.701
1		Body	EN-JL1040, EN-GJL-250	EN-JS1049, EN-GJS-400-18U-LT	GP240GH+N, 1.0619+N
2	x	Screwed seat ring	X20Cr13+QT, 1.4021+QT		
3		Stud	25CrMo4, 1.7218 -A2B		
4	x	Gasket	Pure graphite (CrNi laminated with graphite)		
5		Bush housing	EN-JS1049, EN-GJS-400-18U-LT		
5.1		Guide bush	X20Cr13+QT, 1.4021+QT		
6	x	Gasket	Pure graphite (CrNi laminated with graphite)		
8	x	Balanced-bellow-unit	X6CrNiMoTi17-12-2, 1.4571 / X5CrNi18-10, 1.4301 / X20Cr13+QT, 1.4021+QT		
9	x	Plug unit	X20Cr13+QT, 1.4021+QT (hardened)		
10		Washer	A2		
11		Hexagon screw	< DN40: A4-70		
11		Head	≥ DN40: X6CrNiTi18-10, 1.4541 / X20Cr13+QT, 1.4021+QT		
12		Bonnet Fig. 700 closed	EN-JS1049, EN-GJS-400-18U-LT		
14		Hexagon nut	C35E, 1.1181 -A2B		
15	x	Gasket	Pure graphite (CrNi laminated with graphite)		
16	x	Sealing-bellow-unit	X6CrNiMoTi17-12-2, 1.4571 / X5CrNi18-10, 1.4301 / X20Cr13+QT, 1.4021+QT		
17		Adjusting plate	EN-JS1049, EN-GJS-400-18U-LT		
18		Head	EN-JS1030, EN-GJS-400-15		
19		Screw joint	11SMn30+C, 1.0715+C		
20		Thread pin	45H - A2B		
21		Guide bush	PTFE-25%C		
22		Guide coupling	X20Cr13+QT, 1.4021+QT		
23		Cylindrical balls	102Cr6, 1.2067		
24		Securing wire	X12CrNi17-7, 1.4310		
25	x	Spring	51CrV4, 1.8159		
26		Spring plate	S235JR, 1.0037		
27		Axial bearing	102Cr6, 1.2067		
28		Pressure plate	11SMn30+C, 1.0715+C		
29		Parallel pin	St		
30		Slotted nut	5.8 - A2B		
31	x	P-Actuator			
31.6	x	Rolling diaphragm	NBR / EPDM		
31.8	x	Collar nut with sealing ring	8-A2B		
		↳ Spare parts			

Information / restriction of technical rules need to be observed!

Operating and installation instructions can be downloaded at [www.ari-armaturen.com](http://www.ari-armaturen.com).

ARI-Valves of EN-JL1040 are not allowed to be operated in systems acc. to TRD 110.

A production permission acc. to TRB 801 No. 45 is available (acc. to TRB 801 No. 45 EN-JL1040 is not allowed.)

The engineer, designing a system or a plant, is responsible for the selection of the correct valve.

Resistance and fitness must be verified (contact manufacturer for information, refer to Product overview and Resistance list).

**Diaphragm-Actuator DMA 400 - DMA 40**

- Rolling diaphragm
- Connection through a central thread
- Spindle connection with a fast coupling
- Delivered with a flow restrictor and 90°-elbow

**Material (Diaphragm):**

EPDM -40°C to +130°C

NBR -40°C to +100°C

**Selection of possible applications:**

- Neutral gases, Vapours and liquids  
(only fluids of group II acc. to Pressure Equipment Directive 2014/68/EU)

Pneumatic Actuator		DMA 400	DMA 250	DMA 160	DMA 80	DMA 40
ØD	(mm)	300	250	210	170	140
H	(mm)	135	90	80	75	75
Weight	(kg)	13,4	8,1	5,1	3,7	2,9

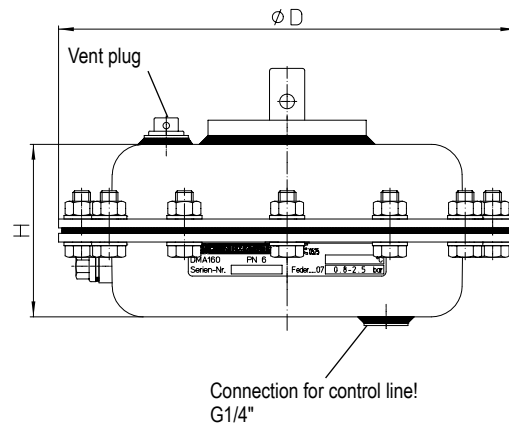

**Water seal pot**

(for media temperatures higher than the allowed diaphragm temperature)

- Delivered with a funnel

**Selection of possible applications:**

- Steam
- Hot water
- Neutral liquids

Pneumatic Actuator		DMA 400	DMA 250	DMA 160	DMA 80	DMA 40
Size		2		1		
ØD	(mm)	140		102		
L	(mm)	110		83		
V	(dm³)	1,2		0,6		

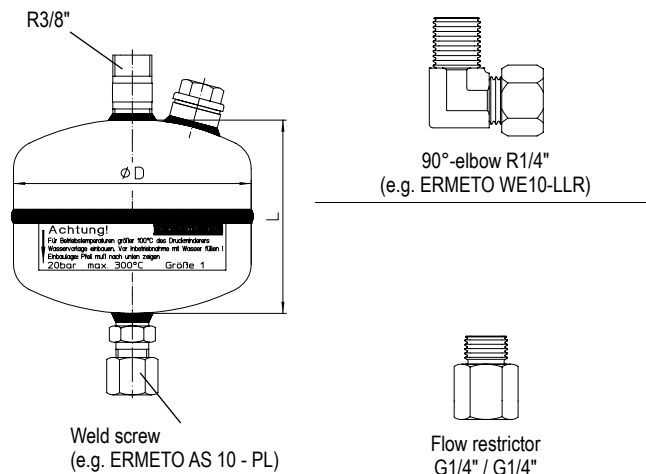

Flow divider for noise reduction



Plug with PTFE soft sealing  
(max. 200°C, only for standard Kvs-values)

**Please indicate when ordering:**

- Figure-No.
- Nominal diameter
- Nominal pressure
- Body material
- Plug version
- Kvs-value
- Pressure range
- Actuator
- Special design / accessories

**Example:**

Figure 35.701; nominal diameter DN 100; nominal pressure PN 40; body material 1.0619+N; metal seal; Kvs 125; 0,8 - 2,5 bar; ARI-DMA 160 with NBR-diaphragm; water seal pot size 1.